

Magnetic Level Gauge PN 16-400/CL 150-2500

Magnetic indicating bar scale with fine resolution, indirect level indication
 Indicating scale above containment
 Indicating elements permanent magnetic with stop pin
 Float magnet field totally circular with strong far field
 Float defect control with indication in lower display end

Product group **710**

Type **22X.0**

Sheet: 1/1

Revision: 1

Date:

9/08

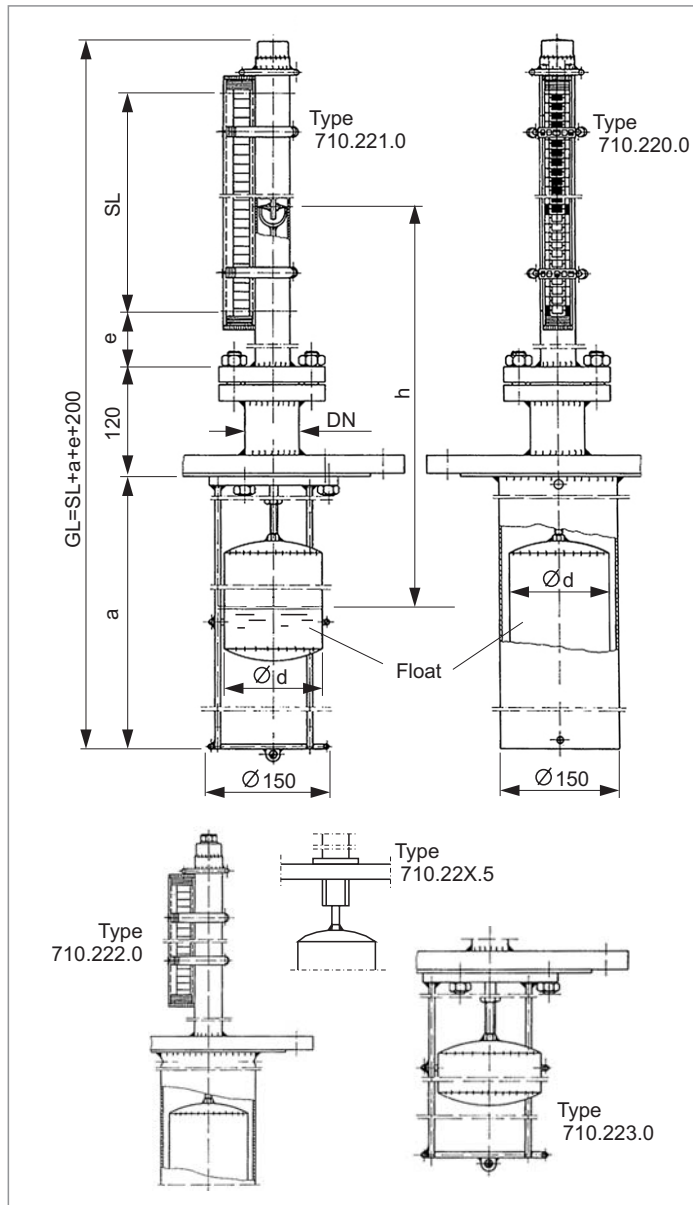

Field of Application

The magnetic level gauge is for indicating the level height or interface of liquids in any vessel. Simultaneously you can use level switches (s. 740.XXXX) or level sensors (s. 745.XXXX) mounted onto the gauge tube to signal level limits or measure the level height by remote control.

General Data

Density .220/1/2/3: from 0,7/0,6/0,7/0,7 g/cm³
 Interface/difference of density: from ±0,1 g/cm³
 Sight length: please request
 Accuracy: ±10 mm
 Viscosity: max 1000 mPas
 Display type: 710.AVG3
 Connection: flange-piece or direct

DN min.220/1/2/3: 40/65/100/125

Material tube, stud, flanges, fixtures, wire/tube guide: SS 1.4571 optional, Hastelloy, Titanium etc
 DIN + ANSI-materials

Float: 1.4571, titanium
 Float Ød .220/1/2/3: 40/56/85/108 mm
 Weight .220/1/2/3: Basic 22,77/18,27/16,77/12,27 kg + 0,72 kg/100mm SL

Design Data

Pressure proc. .220/1/2/3: up to 40,0 MPa
 Temperature media
 Reference vessel compl. 1.4571: -200 ... +400 °C
 flanges 1.0460: -10 ... +400 °C
 Below -10 °C Indicating scale 710.AVG2
 below -20 °C add frost protection with 710.ISOL
 In both cases preparation for insulation included

Certificates

Pressure equipment directive (PED) 97/23/EG
 EC-Type Examination Certificate: TÜV 03 ATEX 2190
 Zone 0

Subject to alterations

Ordering no.

7 1 0 . 2 2 X . X - X X X X - X X X X X

Version	Flange-piece, tube as float guide	0	X	X	X
	Flange-piece, wire as float guide	1			
	direct, tube as float guide	2			
	direct, wire as float guide	3			
	all other connections	0			
	thread connection	5			
Density	z.B. 054=0,54 g/cm ³		X	X	X

Sight length
SL

PHÖNIX

Messtechnik GmbH
 Salzschlirfer Straße 13
 D-60386 Frankfurt/M.
 Tel. +49/69/41 67 42 -20
 Fax +49/69/41 67 42 -29
 sales@phoenix-mt.com
 www.phoenix-mt.com

PHÖNIX